

In de Benelux vertegenwoordigd door **Kotraco Plastic Machinery**

Korte Schaft 23 C • 3991 AT Houten

+31 30 635 0603 • info@kotraco.eu • www.kotraco.eu

**GM250**

**GM250**

**Extrusion blow moulding machines**

Clamping force: 12 kN

Product volumes: 0 — 0,35 l

Shuttle stroke: 150 mm

GM 251 P - Single station / Pneumatic

GM 252 P - Double station / Pneumatic

GM 251 X - Single station / Hybrid

GM 252 X - Double station / Hybrid

General information	Single station machine	Double station machine
Dimensions (Width/Length/Height)	900/1700/2100 mm	1400/2200/2100 mm
Weight	800 kg	1500 kg
Extruder information	Single station machine	Double station machine
Screw diameter	25 mm	32 mm
Extruder drive output	4 kW	7,5 kW
Extruder output HD-PE	7 kg/h	14 kg/h

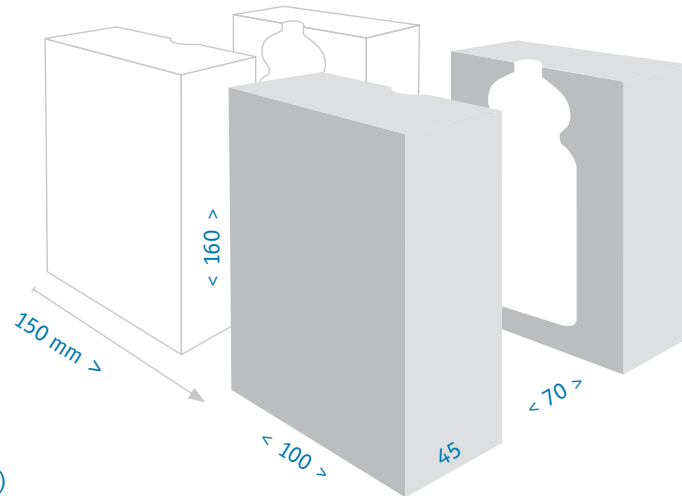

Mould dimensions (mm)

2 Cavities

Standard center distance

50 mm

Technical modifications reserved; Alternative center distances available; Ask for additional equipment. For more information scan QR code or visit website:

[www.gdk.cz](http://www.gdk.cz)

