

In de Benelux vertegenwoordigd door **Kotraco Plastic Machinery**

Korte Schaft 23 C • 3991 AT Houten

+31 30 635 0603 • info@kotraco.eu • www.kotraco.eu

GM750

GM750

Extrusion blow moulding machines

Clamping force: 30 kN

Product volumes: 0—1,5 l

Shuttle stroke: 250 mm

General information	Single station machine	Double station machine
Dimensions (Width/Length/Height)	1200/2400/2400 mm	2000/2700/2400 mm
Weight	1000 kg	1700 kg
Extruder information	Single station machine	Double station machine
Screw diameter	32 mm	40 mm
Extruder drive output	7,5 kW	11 kW
Extruder output HD-PE	14 kg/h	23 kg/h

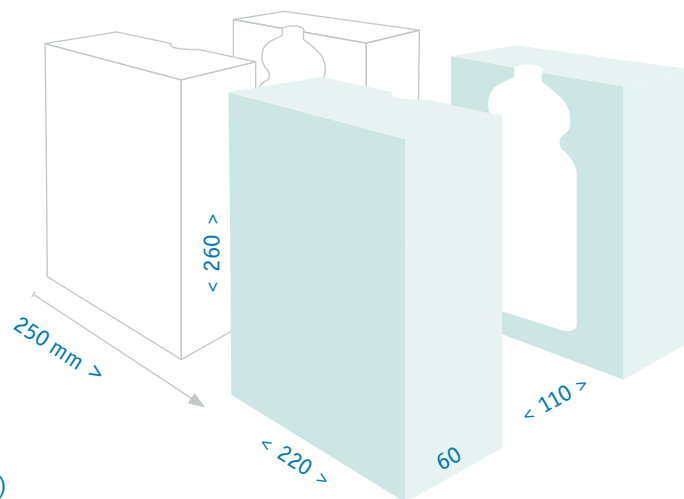

Mould dimensions (mm)

	2 Cavities	3 Cavities
Standard center distance	90 mm	70 mm

GM 751 P - Single station / Pneumatic

GM 752 P - Double station / Pneumatic

GM 751 X - Single station / Hybrid

GM 752 X - Double station / Hybrid

GM 751 E - Single station / Electric

GM 752 E - Double station / Electric



Technical modifications reserved; Alternative center distances available;
Ask for additional equipment. For more information scan QR code or visit website:

www.gdk.cz



GM 751.X– Data Sheet

Clamping force	30 kN
Product volumes	0–1,5 l
Shuttle stroke	250 mm
Extruder information	Single station machine
Screw diameter	32 mm
Extruder drive output	7,5 kW
Extruder output HD-PE	14 kg/h
Drive	hybrid
Mould closing	pneumatic
Carriage movement	electric
Blow pin movement	electric
Parison cutter	pneumatic
Deflashing	pneumatic
Extruder bobbing	pneumatic
Wall thickness control	electric
Dimensions	
Width	1 200 mm
Length	2 400 mm
Height	2 400 mm
Weight	1 000 kg

Standard machine features

- machine design based on over 30 years of experience
- automatic extruder revolution control for precise cycle stability and product quality
- optical sensor of parison length allows direct mould closing for exact position of the parison in the mould
- timer machine mode allows automatic run of the machine, regardless of parison length
- interruption of the automatic machine run causes stop of the extruder and starts the alarm
- the machine is equipped with total cycle counter and daily counter with reset option
- machine is equipped with storage for multiple product data recipes
- every machine is custom made according to customers requirements

Optional features for extra cost

- electric parison 100 point wall thickness control with high precision
- PID temperature controlled feeding zone for steady extruder output
- leak testing unit, which secures output of precise product only
- remote checking of the machine by modem, NET or GSM connection is possible

Main components

SMC, EXLAR, NORD, SANKYO Oilless Industry, Ziehl – Abegg, Wittmann, OMRON, JUMO, Dynisco, Eaton, Murr...

Mould dimensions	2 Cavities	3 Cavities	4 Cavities	5 Cavities
Standard center distance	90 mm	70 mm	-	-

GM750

Extrusion blow moulding machines

GDK spol. s r.o., Czech Republic, 362 14 Kolová 181
 tel. / fax +420 353 331 391, www.gdk.cz

