

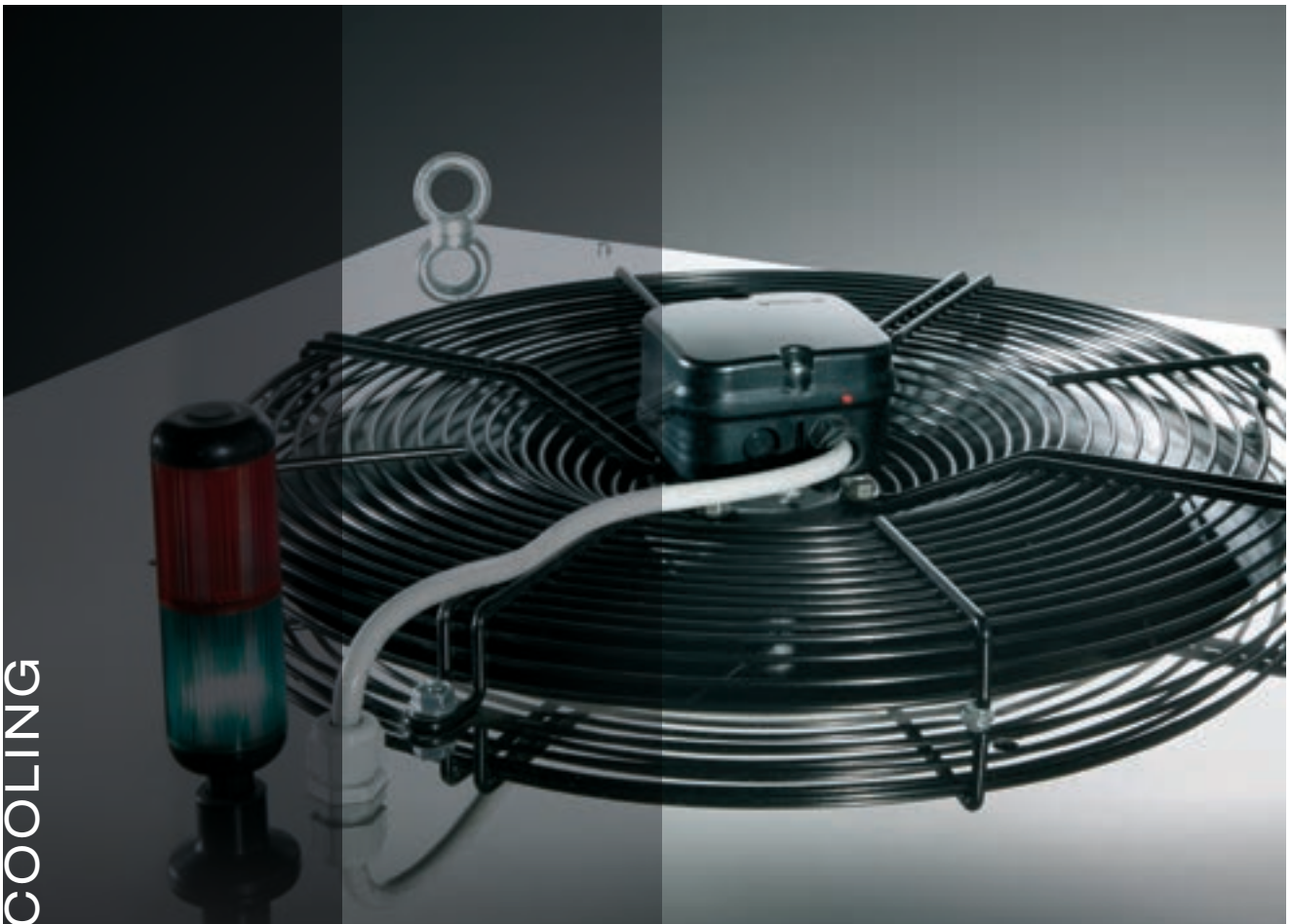

EMPOWERING PLASTICS



COOLING

Product lines
COOLING

ENGLISH / ITALIANO



EMPOWERING PLASTICS



RC MINI SERIES

Cooling

Portable chillers Refrigeratori MINI

- Stainless steel construction
- Scroll compressor
- Integrated tank
- Struttura in acciaio inox
- Compressore scroll
- Serbatoio integrato



Condensation fan.
Ventilatore di condensazione.



kW 6 ÷ 10
kW 15 ÷ 30

RC COMBI SERIES

Combi chillers Refrigeratori Combi

- Stainless steel construction
- Centrifugal fan
- Integrated double pump

- Struttura in acciaio inox
- Ventilatore centrifugo
- Doppia pompa integrata



Combi control panel.
Pannello di controllo serie Combi.



kW 40 ÷ 60
kW 80 ÷ 200



RC COMBI MULTI SERIES

Cooling

Combi chillers Refrigeratori Combi

- High efficiency
 - Stainless steel construction
 - Scroll compressor
 - Double circuit and pump
 - Multi centrifugal fans
-
- Elevata efficienza
 - Struttura in acciaio inox
 - Compressore scroll
 - Doppio circuito e pompa
 - Ventilatori centrifughi

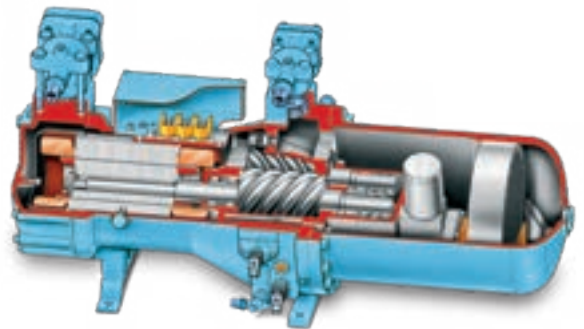

Screw compressor.
Compressore a vite.



XC SERIES

Smart cooling system Sistema di refrigerazione intelligente

- Screw compressor
- Adaptive fans speed
- Large tank capacity
- Multi centrifugal fans
- Compressore a vite a portata variabile
- Velocità dei ventilatori adattiva
- Grande capacità del serbatoio
- Ventilatori centrifughi

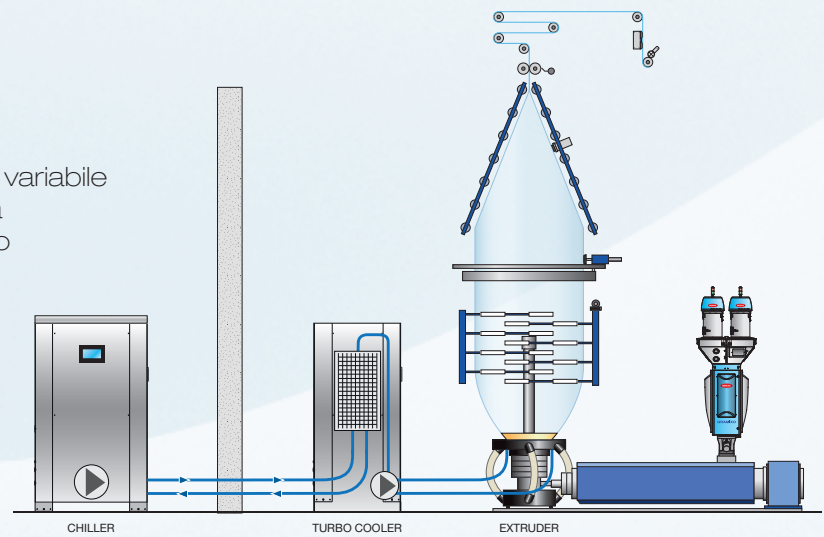

kW 10 ÷ 25



RCV X COOLER SERIES

Cooling

Modulars chillers Refrigeratori modulari

- High C.O.P.
- Very high efficiency at variable loads
- Modularity
- Elevati C.O.P.
- Altissima efficienza a carichi variabili
- Modularità

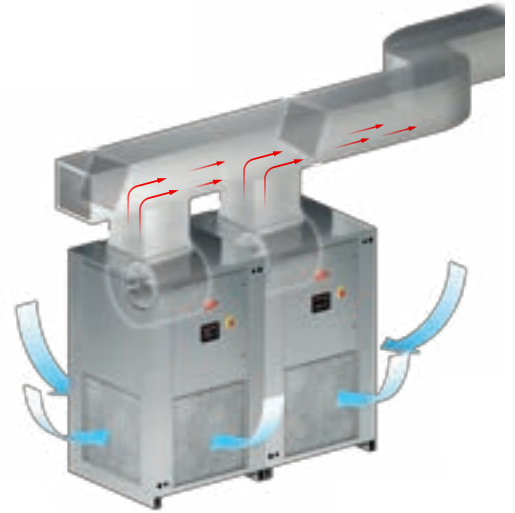

Functional scheme.
Schema di funzionamento.



kW 151

GP SERIES

Pumping groups Gruppi di pompaggio

- High-performance pump
- Standard version:
30% ethylenic water/glycol
- Special version: engines and endurance
for glycol percentage up to 50%
- Pompa ad alte prestazioni
- Versione standard: soluzione
acqua/glicole etilenico al 30%
- Versione speciale: motori e tenute
per percentuali di glicole fino al 50%



Centrifugal pump.
Pompa centrifuga.





GLK SERIES

Glycol loading Caricamento glicole

- Stainless steel pump
- Minimum level
- Automatic filling up
- Pompa inox
- Livello minimo
- Reintegro automatico



TV FREE COOLER SERIES

Free coolers Termoconvettori

- Turbolence batteries
- Axial fans
- Sequential fans control

- Batterie a turbolenza
- Ventilatori assiali
- Controllo sequenziale ventilatori





MOWIS

Cooling

Supervising system Sistema di supervisione



MINI CHILLER



COMBI CHILLER

TEMPERATURE CONTROL



FREE COOLER

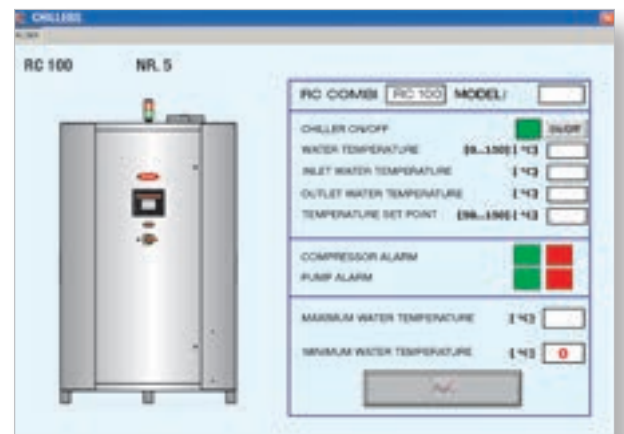



INFOSCREEN

	Server		Client	Total
Temperature control	1	x	32	32
MINI chiller	1	x	32	32
COMBI chiller	1	x	32	32
Free cooler	1	x	32	32

- It controls every operation of the system.
- It records every defect and generates a journal file.
- It sets and/or changes the process parameters.
- It creates process reports in real time.

MOWIS Cooling is an integrated module of a platform which includes:

- Data base of the injection moulding machines.
- Data base of the articles to be produced (codes).
- Data base of the temperatures.

It manages 3 levels of password:
User - Super User - Administrator

- Sorveglia ogni operazione del sistema.
- Registra ogni anomalia e crea uno storico.
- Imposta e/o modifica parametri di processo.
- Crea report di processo in tempo reale.

MOWIS Refrigerazione è un modulo integrato di una piattaforma che include:

- Data base macchine trasformatrici.
- Data base articoli da produrre (codici).
- Data base temperature.

Gestisce tre livelli di password:
User - Super User - Administrator

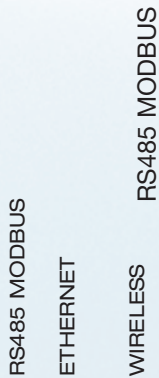

Remote control with wireless device.
Controllo remoto con dispositivo wireless.





A series of horizontal dotted lines spanning the width of the page, providing a guide for writing or editing text.

Standard

- Hopper loaders
- Hot air dryers
- Dehumidifying dryers
- Grinders
- Microdosing units
- Volumetric dosing units
- Gravimetric dosing units
- Storage bins
- Temperature controllers
- Chillers
- Free coolers
- Supervising

Centralized Systems

- Conveying
- Dehumidifying
- Dosing
- Storage
- Cooling
- Supervising (MOWIS)
- Optical disc
- Pet
- Medical
- Packaging
- Bioplastic
- Powder compounding

On behalf of the Moretto staff, we should like to thank you for the time you have dedicated to reading this presentation. Numerous people have made invaluable contributions to our work with their suggestions, ideas and tips, spurring us on in the search for new solutions. We should also like to thank all our customers who have purchased our products over the years, giving us the opportunity to express our full potential. With you and all our future customers, we are committed to constantly improving our products and to providing customized solutions. We therefore reserve the right to update any data or technical information in this catalogue at any time without prior notice.

Vi ringraziamo, a nome di tutto lo staff Moretto, per il tempo che ci avete dedicato nello scorrere questa presentazione. Tante sono le persone che con suggerimenti, idee e spunti contribuiscono al nostro lavoro, stimolandoci nella ricerca di nuove soluzioni. Un sincero ringraziamento va inoltre a tutti coloro che in questi anni hanno scelto i nostri prodotti consentendo di esprimerci al meglio. Con tutti voi e con quanti vorranno ancora preferirci, ci impegniamo a migliorare continuamente la nostra offerta e a fornire soluzioni sempre su misura. Nell'ottica di un continuo miglioramento, ci riserviamo la facoltà di aggiornare in qualsiasi momento dati e informazioni tecniche dei prodotti illustrati nel catalogo. Grazie per l'attenzione prestataci.

Vertegenwoordiging Benelux:



Korte Schaft 23 C • NL-3991 AT Houten
T +31 (0)30 635 0603 • E info@kotraco.eu
www.kotraco.eu

Plastic Machinery

designed by Moretto



MORETTO S.p.A.

VIA DELL'ARTIGIANATO, 3
35010 MASSANZAGO (PD) ITALY
TEL. +39 049 9396711 r.a.
FAX +39 049 9396710
www.moretto.com

MORETTO DEUTSCHLAND

info@moretto-deutschland.de
www.moretto-deutschland.de

MORETTO EAST EUROPE

info@morettoeasteurope.com
www.morettoeasteurope.com

MORETTO TURKEY

info@morettoturkey.com
www.morettoturkey.com

MORETTO DO BRASIL

info@morettodobrasil.com.br
www.morettodobrasil.com.br

MORETTO U.S.A.

info@morettousa.com
www.morettousa.com

MORETTO RUSSIA

info@moretto.ru
www.moretto.ru

MORETTO INDIA

info@moretto.com
www.moretto.in

MORETTO CHINA

info@moretto.com
www.moretto.cn